

Signal Levels and Stability Tests in the NanoBPM Project

Mark Slater
Cambridge University

ATF Mini-Workshop, 31/5/05

Overview

- Summary of current electronics used by NanoBPM
- Comparison of calculated Signal levels and Noise figures with those found from measurement
- Stability tests for Spectrometer feasibility study

Overview of SLAC Electronics

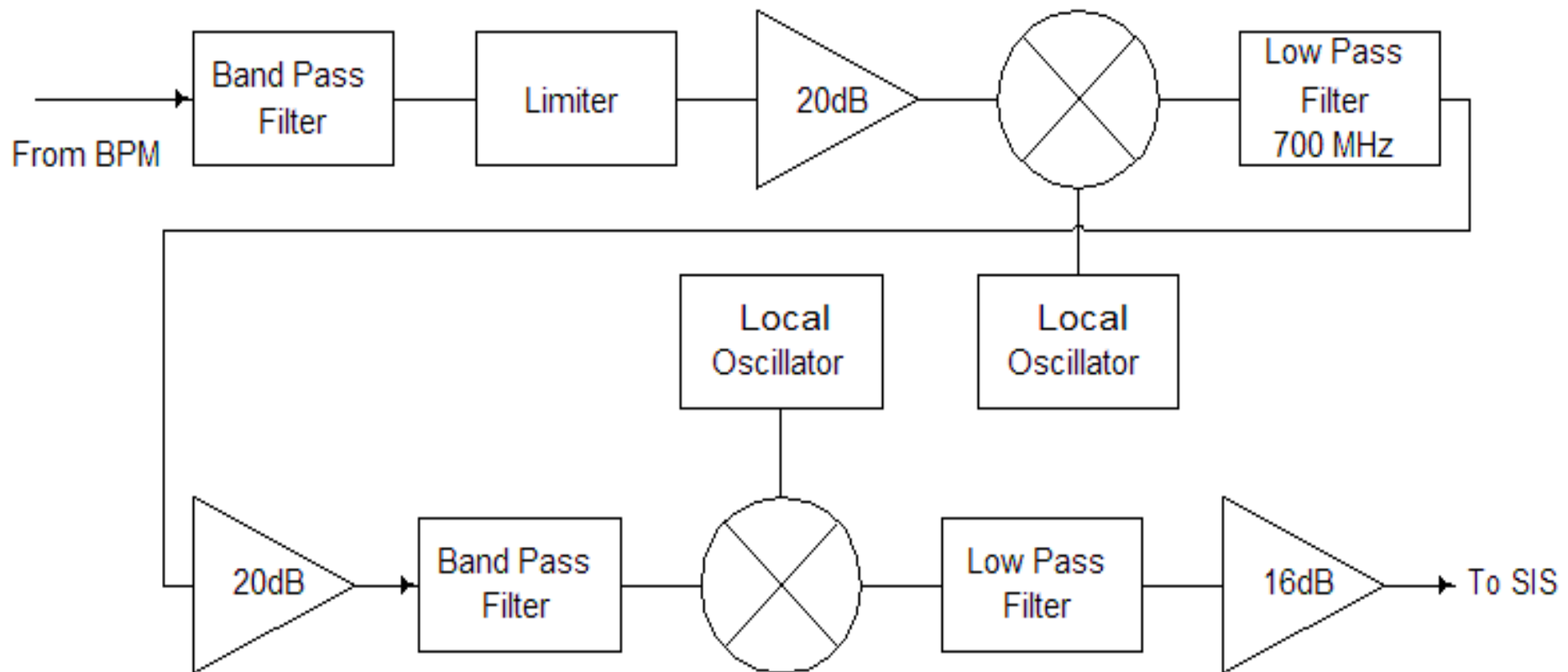

- 2 Stage Downconversion
- 3 Stages of Amplification

Signal Levels

- Thermal Noise Level Calculated made using:
 - 20MHz Bandwidth
 - 293 K Temperature
- And the following equation:
 - $P = kTB$
- Overall noise power calculated to be **-100.9 dBm**
- Two signal levels calculated:
 - 1 μm offset (giving a signal of **-50.7 dBm**)
 - 1 mm offset (giving a signal of **9.6 dBm**)

Signal Levels, cont.

- Overall Noise Figures were calculated using 'Friis's Formula':

$$F = F_1 + (F_2 - 1)/G_1 + (F_3 - 1)/G_1 G_2 + \dots$$

where F is the Noise Factor and G is the Gain of a particular stage, both of which are dimensionless (i.e. a ratio).

Signal Levels

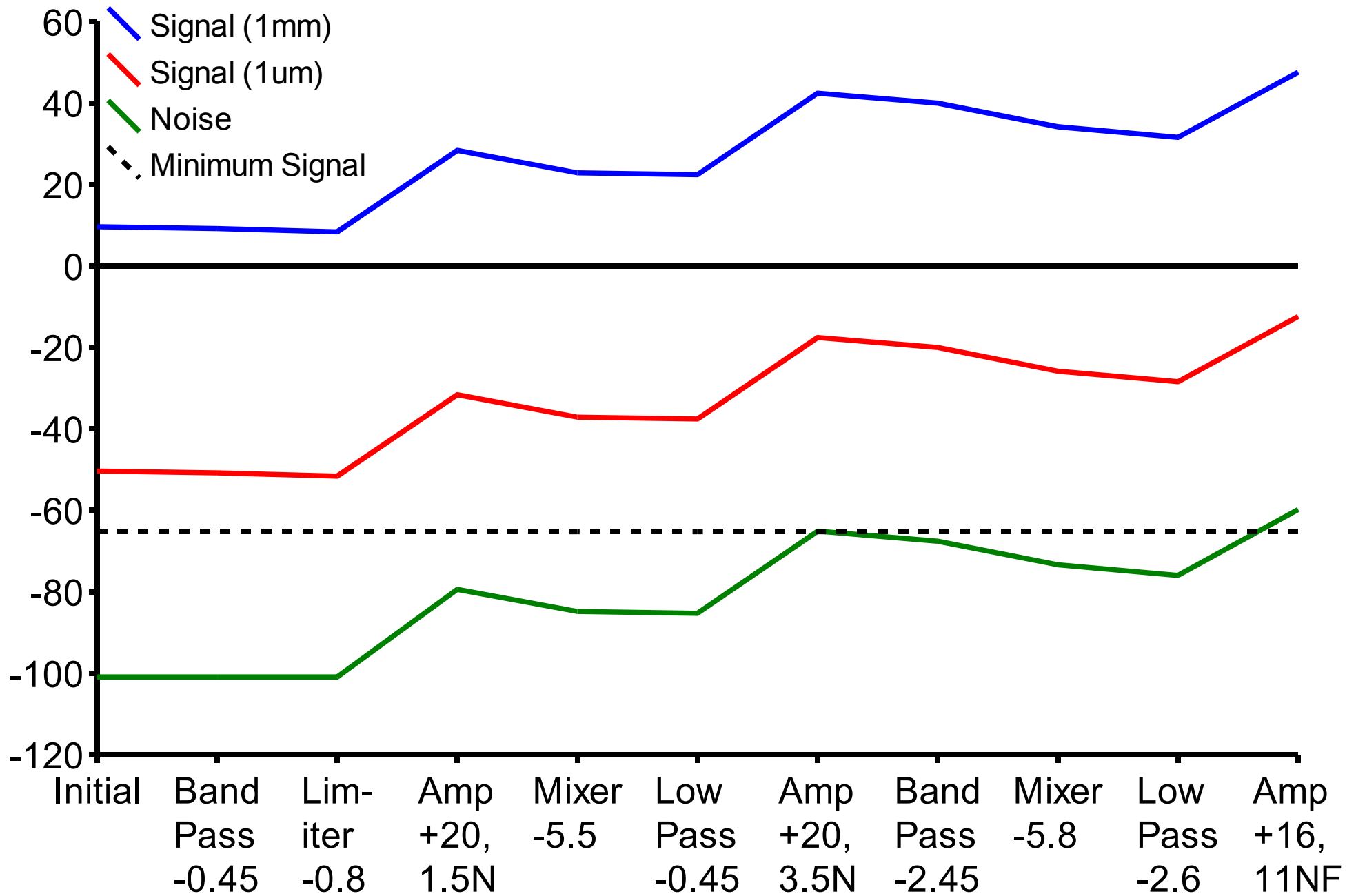

Comparison with Gain Measurements

- The theoretical gain can now be compared with the measurements made by Steve Malton
- The gain factors are:
 - Theoretical gain: 39.0dB
 - Measured gain: 44.4 ± 1.2 dB (error given by channel variation)
- The reason for the 5dB difference is currently unknown
 - Amplifier response?
 - Smaller Insertion Losses?
- More investigation is required...

Comparison of Noise Figures

- To compare the computed and measured noise figures, the noise was measured at the ADCs by both myself and Alexei
- To do this, the pedestal noise was found from the beginning of the signal waveforms:

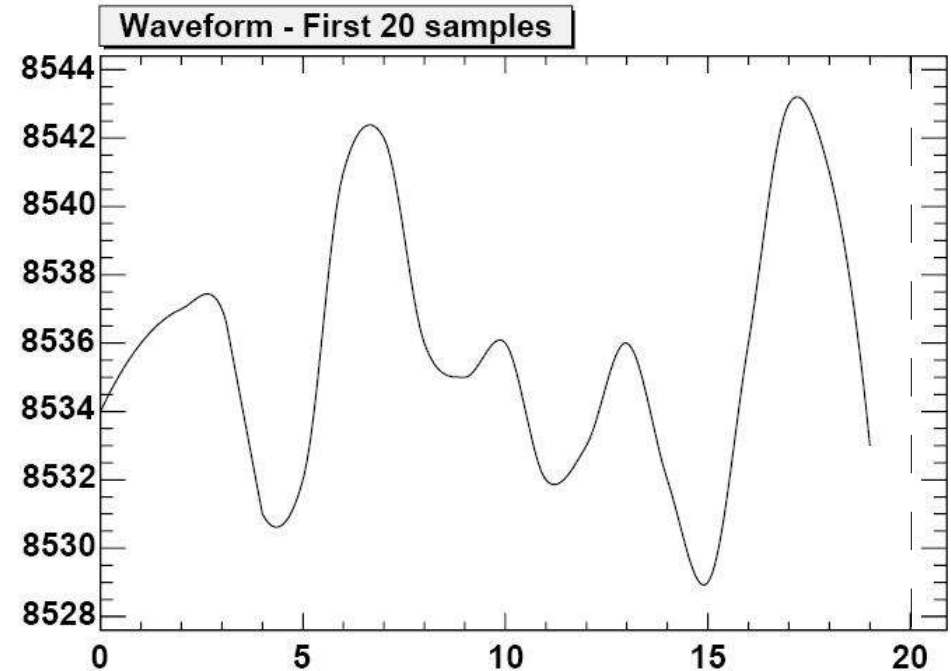
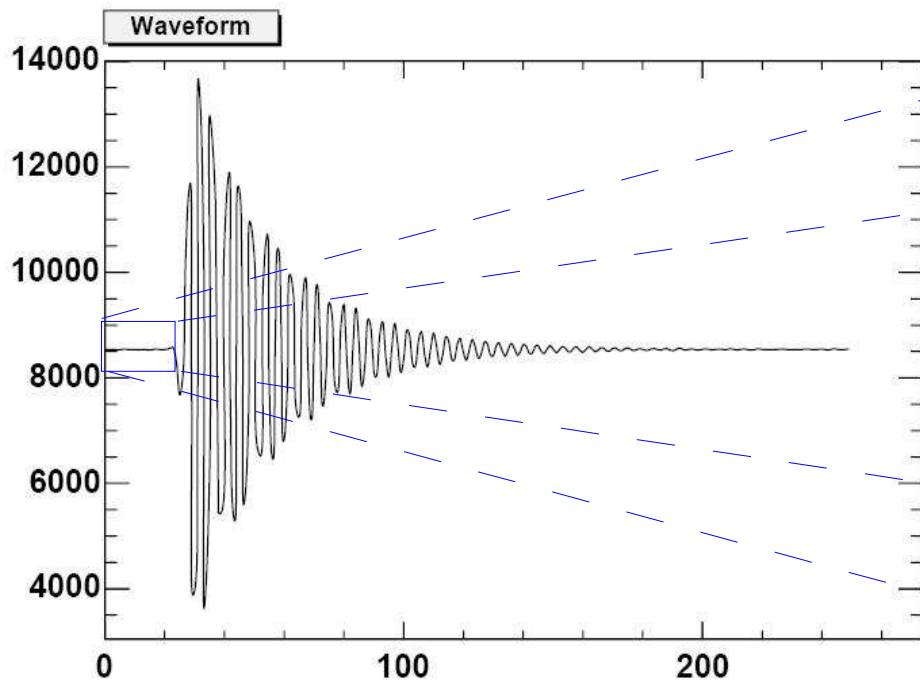

Observed Noise, cont.

- The RMS value of 2000 pulses was found from the first 20 samples
- Averaging over the 6 BPM channels gave an RMS of ~ 4.5 counts
- This corresponded to an observed noise of $-52.2 \pm 0.4 \text{ dB}$ where the error is given by the variation seen on the 6 BPM channels
- Combining this with the measured gain gave a Noise Figure estimate of $4.5 \pm 1.3 \text{ dB}$
- This is a little higher than the predicted value of 3.1 dB
- **BUT:** This does not include the noise generated by the ADCs

Signal Level Conclusions

- The response of the Gen. 2 electronics has been measured and compared with theory
- Theoretical S/N ratio:
 - 107.5 dB (1mm)
 - 47.8 dB (1 μ m)
- There is a significant difference between the predicted and measured gains which still needs to be understood
- A similar method needs to be carried out on the Gen 1 electronics used with the KEK BPMs

Stability Checks

- The stability of the BPMs needs to be measured to check their feasibility for use in the Energy Spectrometer at the ILC
- Require a stability of $\sim 100\text{nm}$ over 1 hour (see Mike Hildreth's talk)
- There are two checks currently underway, (with more planned):
 - Stability of IQ phases and scales over the course of 2 weeks
 - Stability of resolution over long running periods

Some Background

- The **Fitting Algorithm** extracts the amplitude and phase information from a specific pulse by fitting an exponentially decaying sine wave
- The algorithm I'm currently using is based on the code developed by Sean Walston
- The calibration schemes are used to extract:
 - **Frequencies and Decay constants**
 - **IQ Phases:** Describes the relation between the In-phase and quadrature components of a pulse and the measured positions and tilts
 - **Scales:** Calibrates the overall range of the BPM

IQ Phase and Scale Stability

- Several calibration runs have been taken over the last week to check the stability of both the IQ phases, Scales and the fitting algorithm itself
- The Frequencies and Decay Constants extracted from the fitting algorithm were found to vary by $\pm 0.1\%$ and $\pm 0.2\%$ respectively
- However, some pulses were found to have frequencies significantly different from the mean values
- This indicated a possible problem with the fitting algorithm being used

X and Y Cross-Talk

- As can be seen below, there appeared to be two frequencies in the Y couplers
- One of these was found to match the frequency of the X polarisation and so cross-talk between the polarisations seemed to explain this behaviour

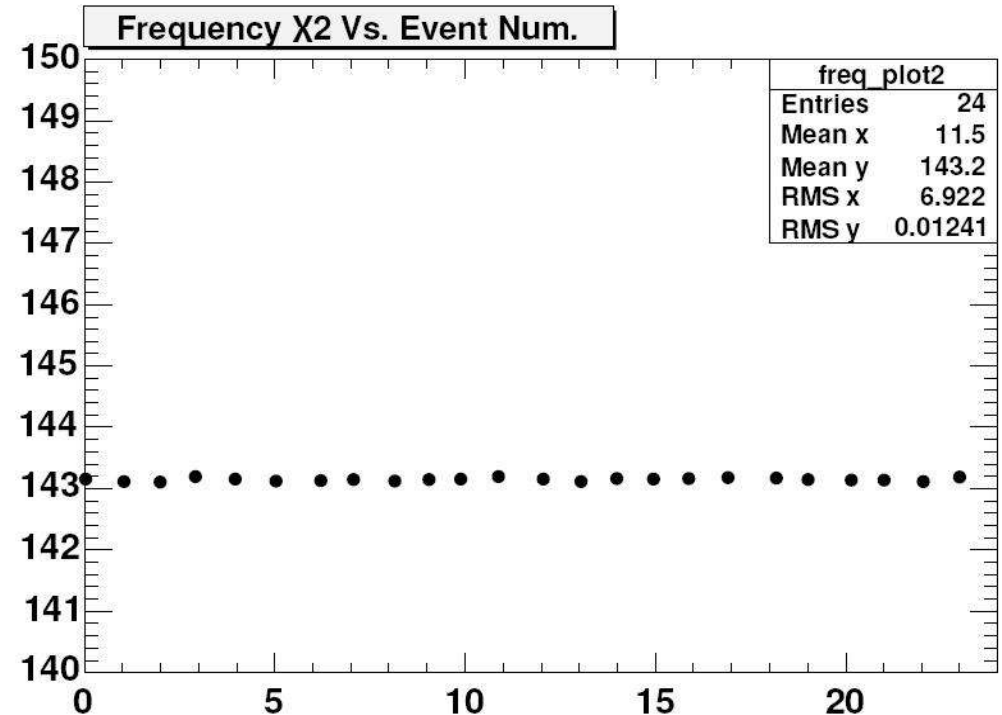
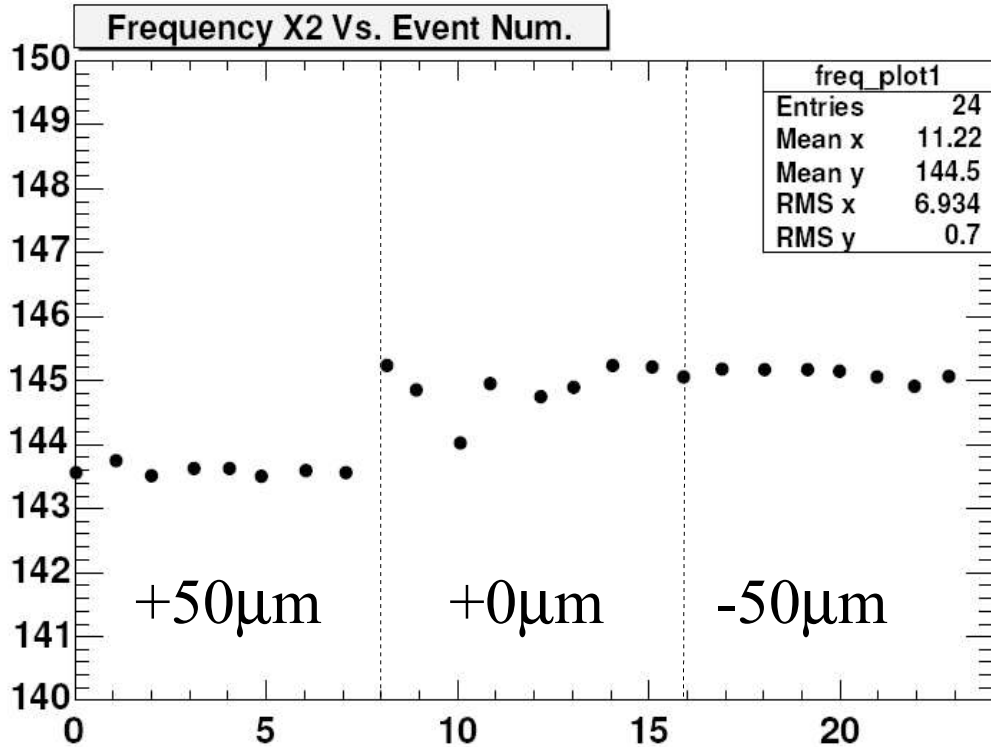

X and Y Cross-Talk

- From this investigation, it was found that different frequencies dominated depending on the beam location in the BPM
- In regions where the amplitude of both frequencies were comparable, beating is seen ('fish' plots)
- More investigation is needed to quantify the amount of cross talk between the two polarisations

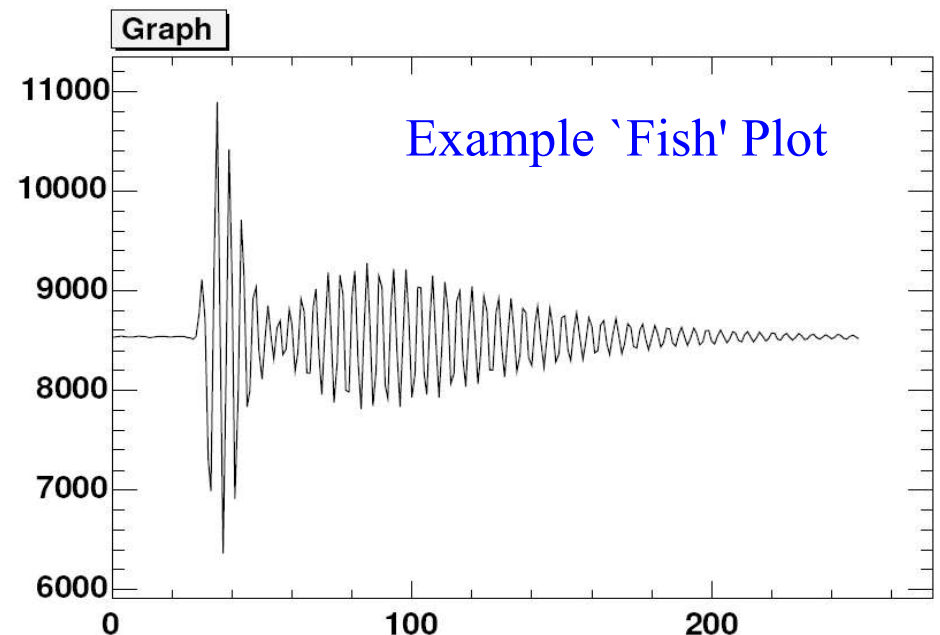
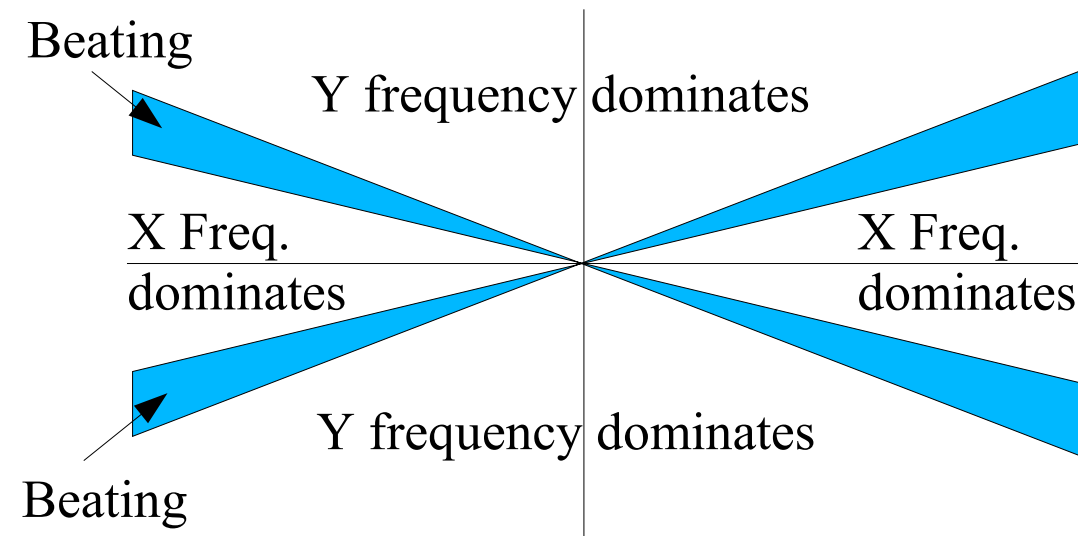

IQ Phase Stability

- From the multiple calibrations taken, the IQ phase was found to vary by $\pm 1\%$ over 2π
- Using data from the March run, the variation of resolution with IQ phase has been investigated:

IQ Phase changes by ± 0.063

→ Resolution changes by 2nm

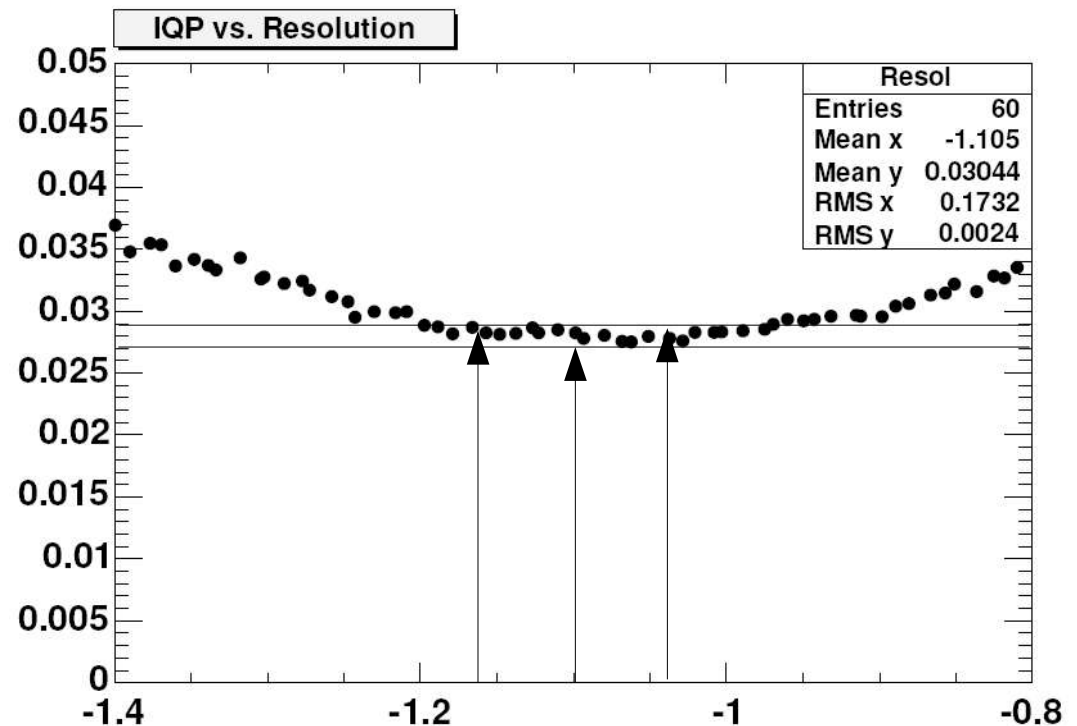

Scale Stability

- Over the course of the 5 calibration runs taken, the scale factor was found to vary by $\pm 20\%$
- This is considerably larger than the other variables
- This could indicate limitations in either the **Fitting Algorithm** used or the **reduced calibration scheme** used

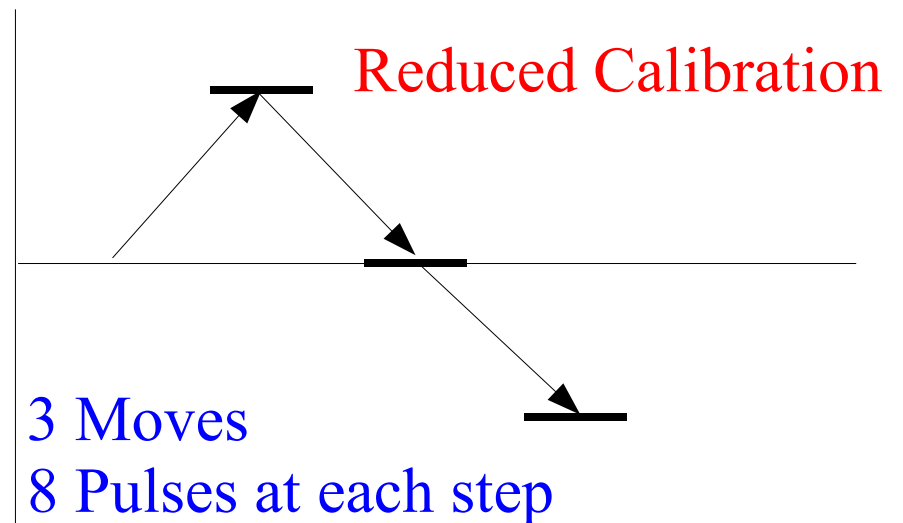
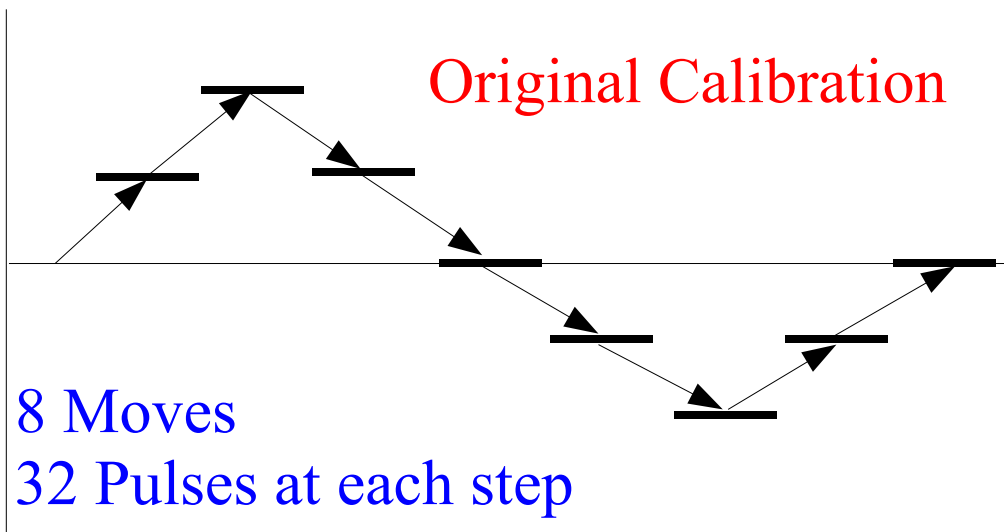

Stability over ~2 hours

- On Friday, a long run of ~ 2 hours was taken
- This has been analysed by Steve Smith and the variation in resolution during the period found:

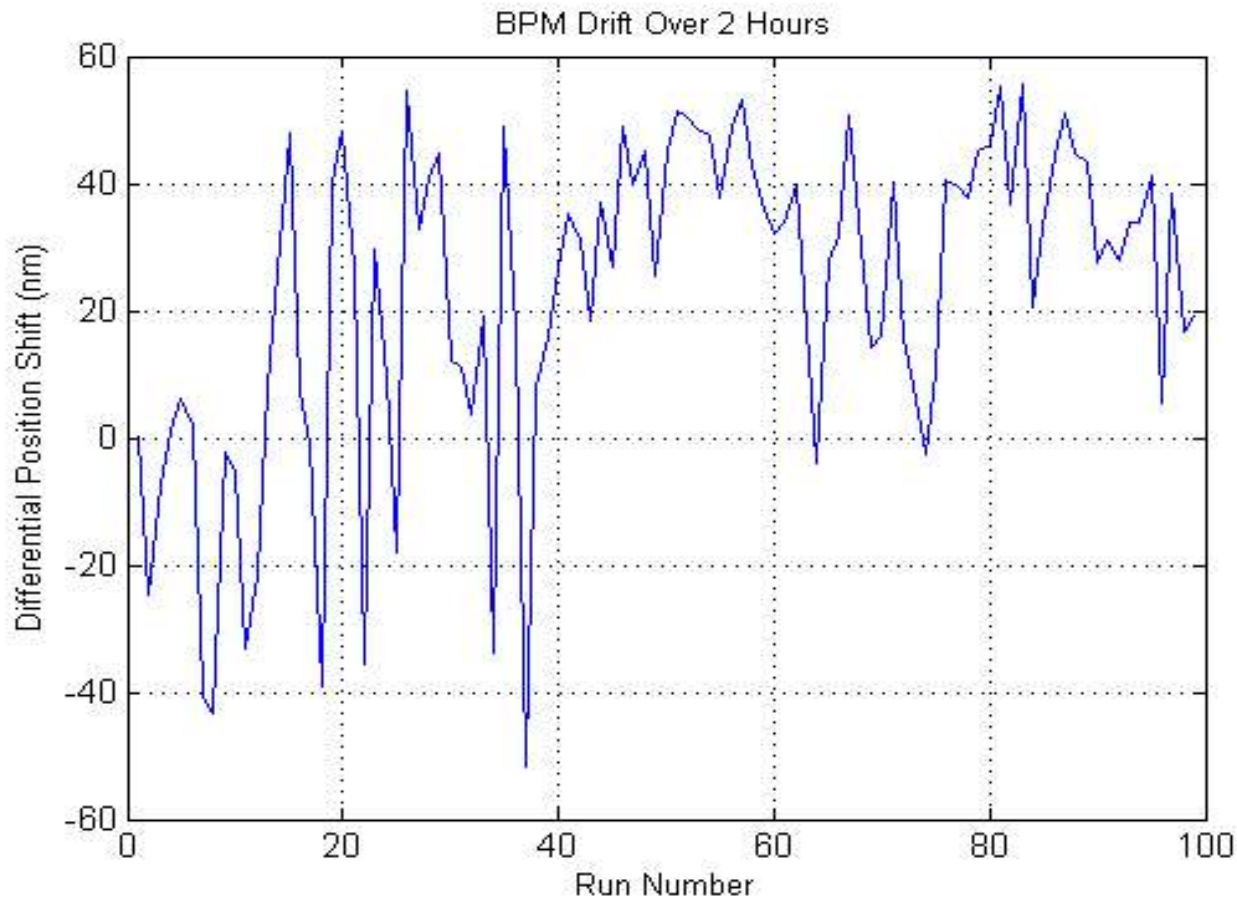

Stability Conclusions

- Tests of the BPM stability have been started
- Analysing a number of different calibration runs have shown the following stabilities:
 - Frequency: $\pm 0.1\%$
 - Decay Constant: $\pm 0.2\%$
 - IQ Phase: $\pm 1\%$
 - Scale: $\pm 20\%$
- This method has highlighted some possible limitations of the algorithm/calibration scheme that are currently under investigation
- A 2 hour run has been analysed by Steve Smith and this shows a variation of $\sim 40\text{nm}$
- More stability checks are planned...